

Application

CJX7-9 ~ 300AC contactor(hereafter refer to as contactor) is mainly used in power system with AC 50Hz(or 60Hz),therated working voltage up to 660V,under the applicaton category of AC-3,when the rated working voltage 380V,the rated operating current to 300A electrical,for the long-distance range making and breaking the electric circuit,and combines the electromagnetism starter with the suitable thermal overload relay or the electronic protector to protect against the possible overload electric circuit during operation(running).

Type and Meaning

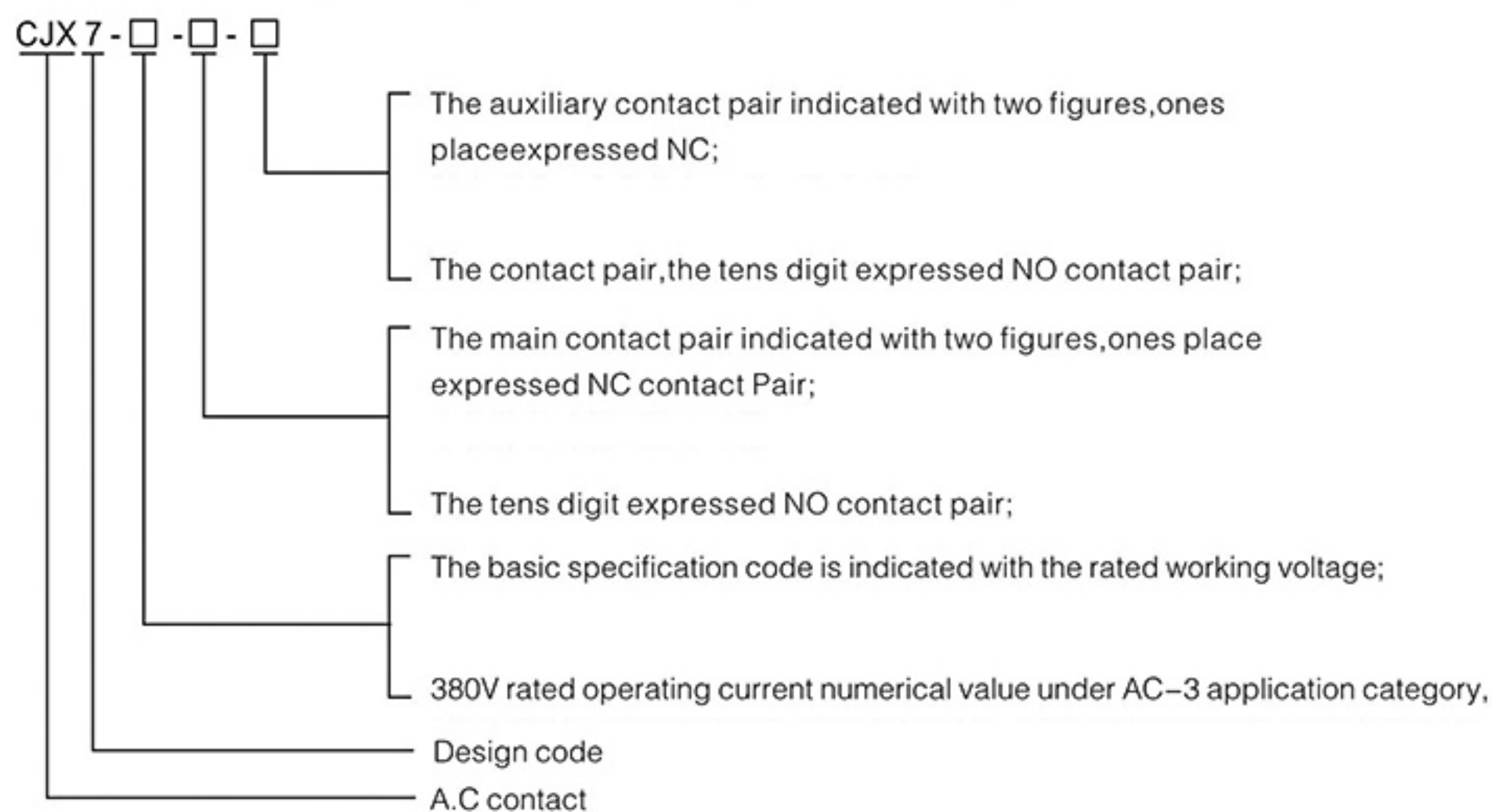

Main structure and working principle

- 3.1 The structure of the contactor is the positive mounted straight action type double-break dots,cover and the body are made by the arc proof plastic,CJX7-9-16 uses the auto extinguishing of arc,but CJX7-26~110 has "U"shape the extinguishing of arc piece in the body to form the seal explosion chamber. The extinguishing of are is good,the arc over distance is zero.The contact is made by the anti-fusion welding and bears the silver base alloy material wear electricity with good electric conductivity,long life,does not have the pollution to the environment.The ferrite core has"E"shape structure,small vloume. There are two kinds of coil wiring ways for the user choice,one is the two terminals in the identical end of the product;other is the two terminals in the product° Φs beginnings and ends,the wiring is flexible and convenient. The base is made by the glass fiber reinforced plastics with high intensity,good dielectric properties.The installation way can be the bolt,also may use the guide rail installment.The idsassemble and assemble are very convenient and rapid.The electric conduction part does not appear externally,the security performance is good.
- 3.2 The working principle of contactor:control power source of making(breaking) contactor pullin coil,magnetism system produces(vanishes) electromagn- etism suction to drive the moving part making and(breaking) circuit through then,realize the goal of control.

Common Work Condition And Installing Condition

- a. The installation site elevation does not surpass 2000m;
- b. Ambient air temperature should not over +40°C, also not over +35°C within 24h, the lower limit of ambient air temperature is -5°C;
- c. The air relative humidity at installation site should not over 50% when the maximum temperature is +40°C; the higher relative humidity are allowed under lower temperature, for example, 90% at 20°C, It must take the measures on the product occurring dew because of the change of temperature.
- d. The installation site pollution class is 3;
- e. The contactor can be mounted vertically or horizontally. If vertically mounts, the gradient between the mounted surface and the perpendicular plans is not bigger than $\pm 30\%$; (See Fig 1)

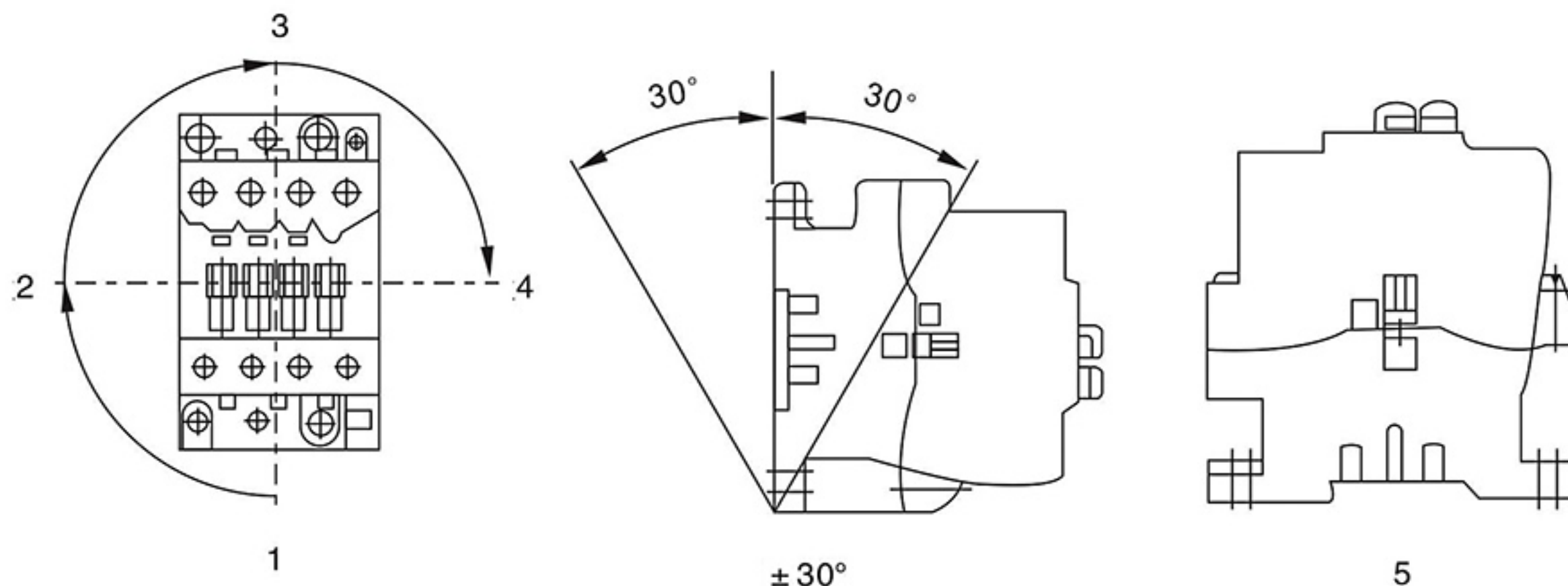

Technical parameter

5.1 The allowable application category of main circuit and the auxiliary circuit of the contactor and it's code see Table 1

Table 1 application category of main circuit and the auxiliary circuit of the contactor and it's code

Circuit	Application category code	Example of the typical usage
Main Circuit	AC-1	Noninductive or the micro inductive load, resistance furnace
	AC-2	The starting and breaking of wire winding type asynchronous motor
	AC-3	The starting and breaking during operation of cage asynchronous motor
	AC-4	The starting, plug breaking or reverse revolution, spot moving of cage asynchronous motor
Auxiliary circuit	AC-15	Control AC electromagnet load (> 72VA)
	DC-13	Control DC magnet load

5.2 Contactor rated insulation voltage(Ui), rated working voltage(Ue), conventional free air heat current(Ith), rated operating current(Ie) and rated work rate see Table 2.

Table 2 main circuits basic parameters

Type	Frame code	Rated insulation voltage UiV	Conventional free air heat current Ith	AC-3rated operating current Ie A			AC-3 control the max.power KW of generator		
				220V	380V	660V	220V	380V	660V
CJX7-9	16	1000	26	9	9	7	2.2	4	5.5
CJX7-12			28	12	12	9	3	5.5	6.5
CJX7-16			30	17	17	10	4	7.5	9
CJX7-26	26		45	26	26	17	6.5	11	15
CJX7-30			65	32	32	21	9	15	18.5
CJX7-40	40		65	37	37	25	11	8.5	22
CJX7-50			100	50	50	35	15	22	30
CJX7-63	75		125	65	65	43	18.5	30	37
CJX7-75			125	75	75	46	22	37	40
CJX7-95	110		145	96	96	65	25	45	55
CJX7-110			160	110	110	82	30	55	75
CJX7-145	185		250	145	145	120	40	75	100
CJX7-185			275	185	185	170	50	90	120
CJX7-210	300		350	210	210	210	60	110	150
CJX7-260			400	260	260	260	78	140	190
CJX7-300		450	300	300	280	88	160	220	

Installation

6.1 Correct install wiring

Note that the terminal symbole:Main circuit 1L1,3L2,5L3 is incoming terminal:2T1,4T2,6T3 outgoing terminal.

The incoming terminal of NO auxiliary contact is:13,23,33,43.....the outgoing terminal of NO auxiliary contact is:14,24,34,44.....The outgoing terminal of OFF auxiliary contact is:11,21,31,41.....the outgoing terminal of OFF auxiliary contact is:12,22,32,42.....The coil terminal is:A1 and A2

6.2 Contactors Overall and installation dimensions see Figure 2,Figure3,Figure4,Figure5 and table9.

External dimensions and installation dimensions

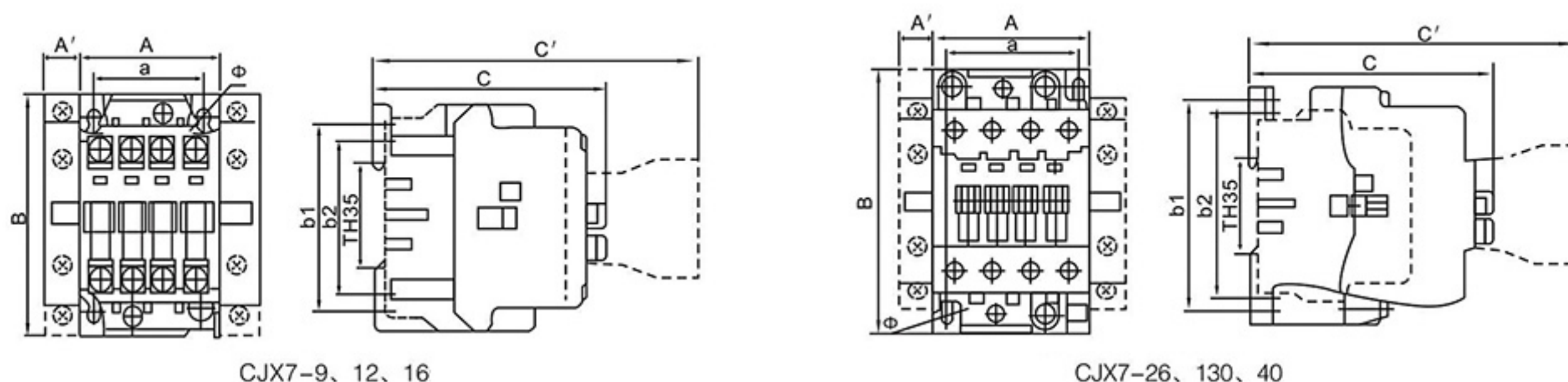

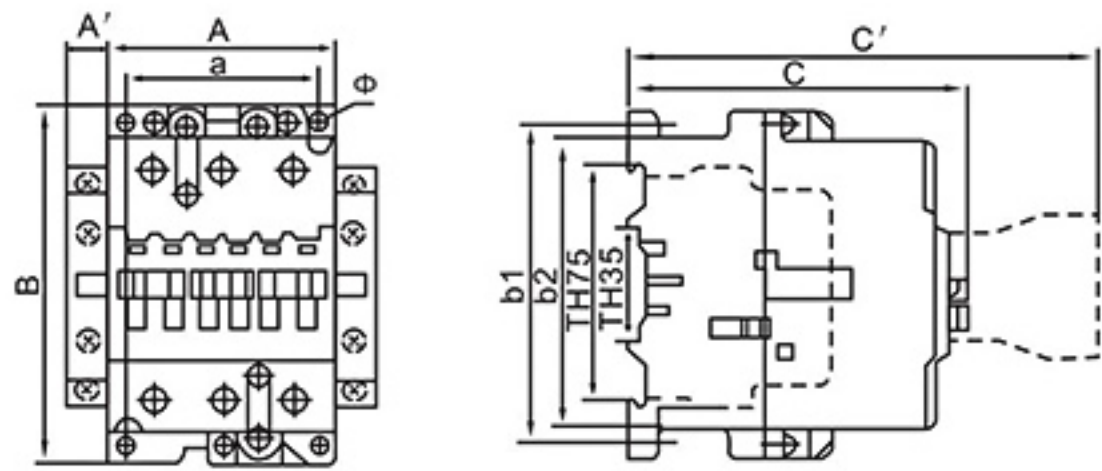

CJX7-50, 63, 75

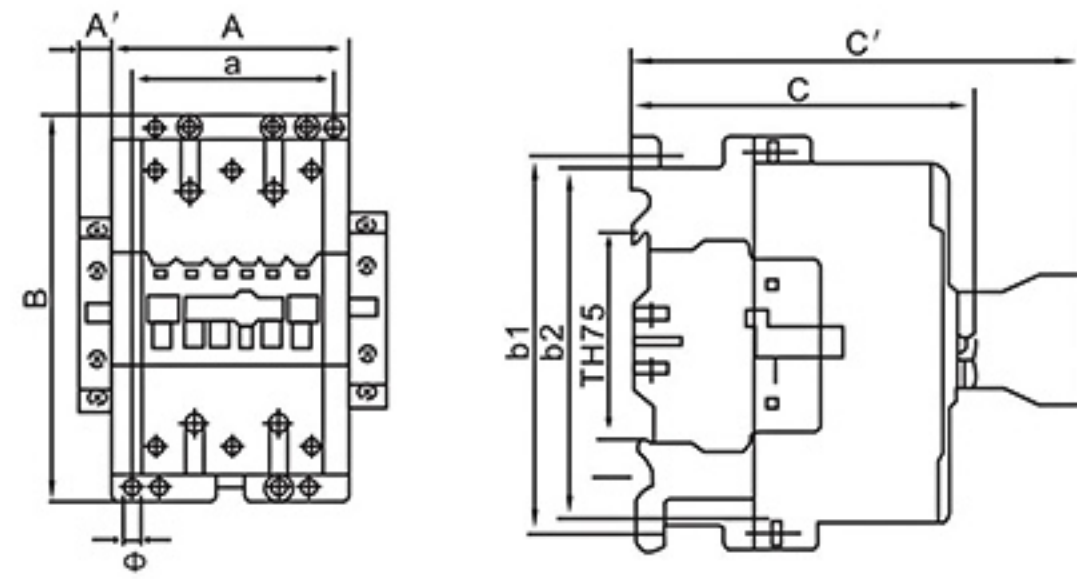

CJX7-95, 110

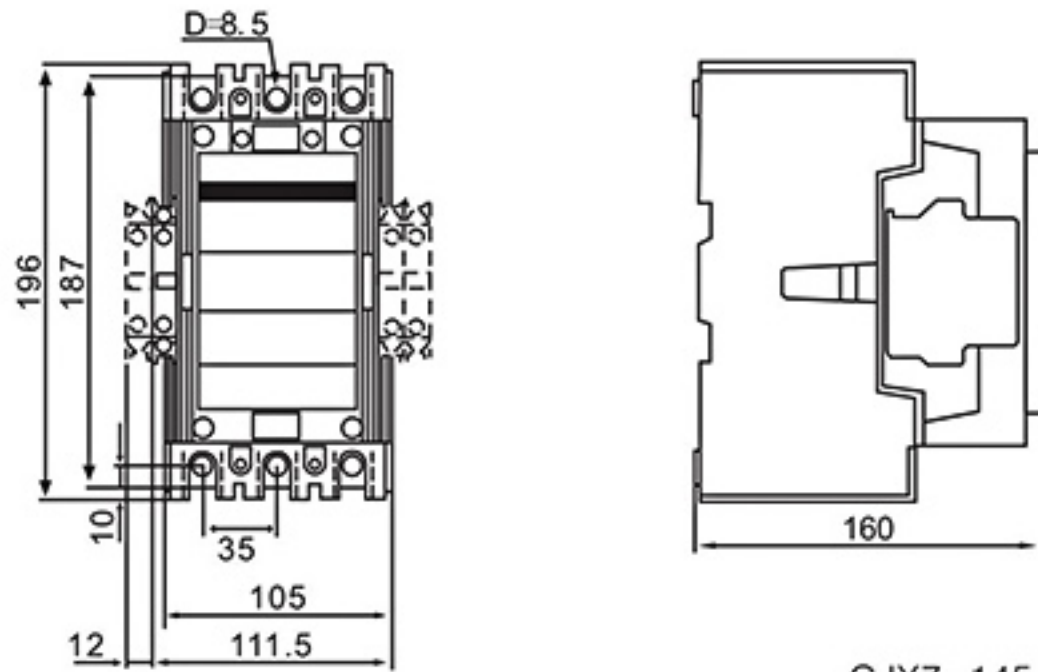

CJX7-145, 185

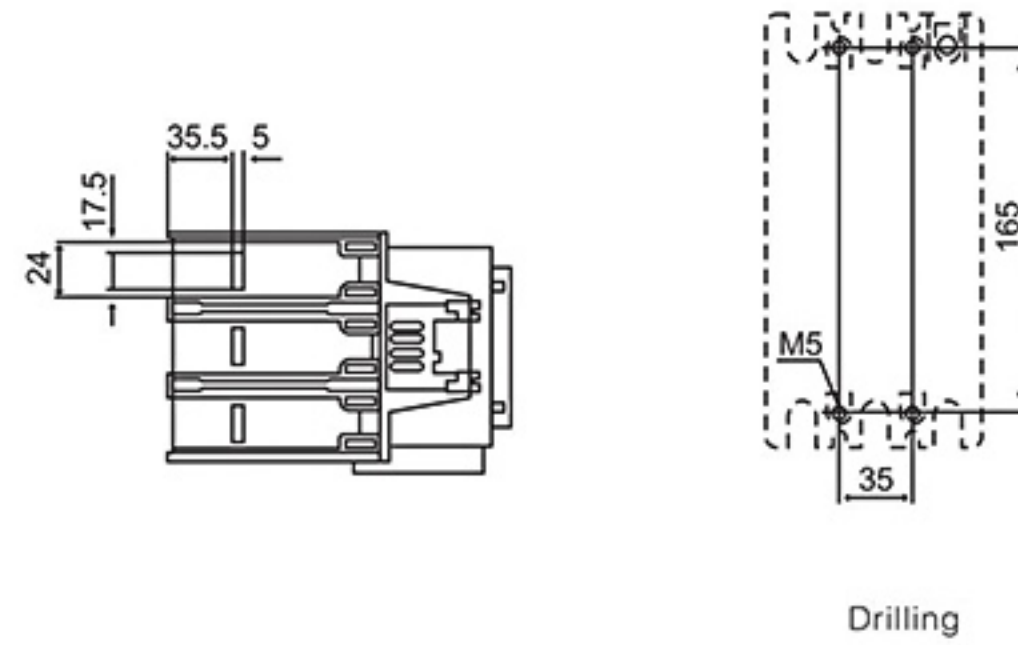

Drilling

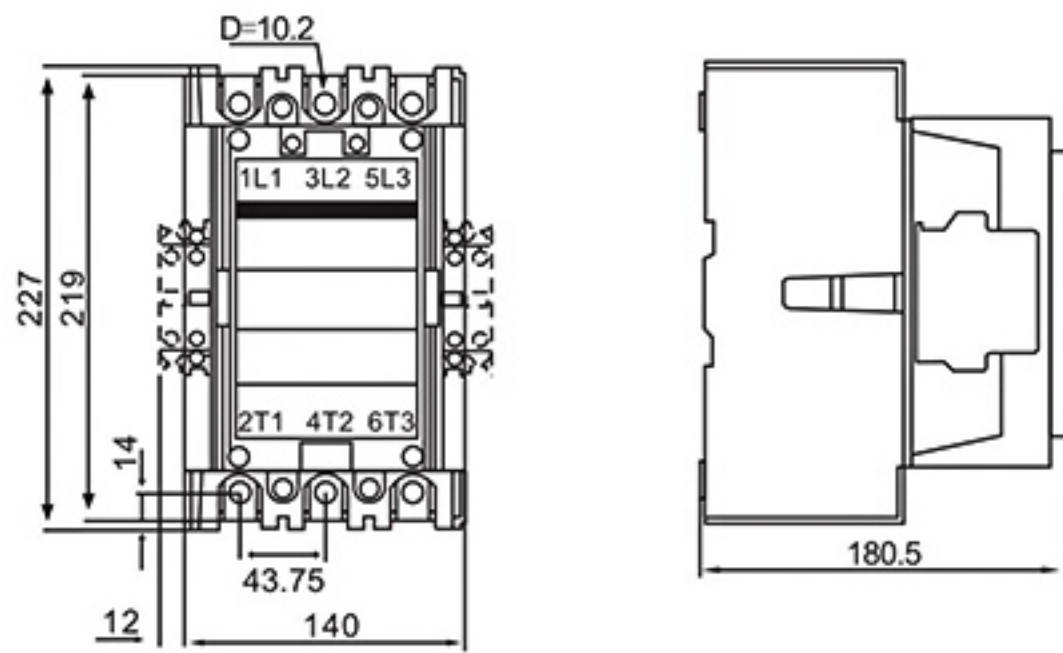

CJX7-210, 260, 300

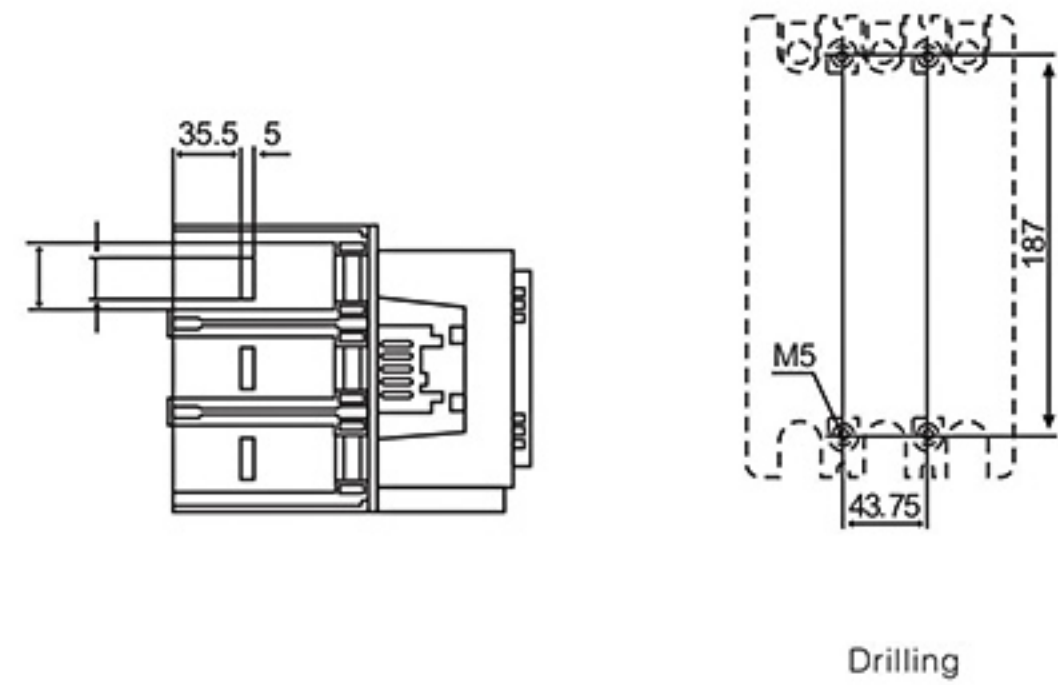

Drilling

Type	A	A'	B	C	C'	a	b1	b2	Φ	Mounting mode
CJX7-9,12,16	44	12.5	74	74	102	35	60	50	4.5	Screw installation or TH75 mounting rail installation
CJX7-26	54	12.5	90	93.5	120.5	45	80	70	4.2	
CJX7-30,40	54	12.5	90	108.5	135.2	45	80	70	4.2	
CJX7-50,63,75	70	12.5	110	108	135	60	100	90	6.2	installation or TH35 or TH75 mounting rail installation
CJX7-95,110	90	12.5	148.5	123.5	151	78	136	126	6.2	Screw installation or TH75 mounting rail installation
CJX7-145,185	Note:Refer to drawing 6 for dimension									
CJX7-210,260,300	Note:Refer to drawing 7 for dimension									